

| | |
|--------------------|---|
| VORSCHUBART | |
| MECH. VORSCHUB | X |
| MAN. VORSCHUB | |

| | |
|------------------------|--|
| DREHZAHLBEREICH | |
| n max. 24.000 U/min | |

| | | |
|---------------------------------|----------|---|
| Material für Grundkörper | | |
| V 155 | Densimet | X |

* Bestückungshöhe: 3 mm

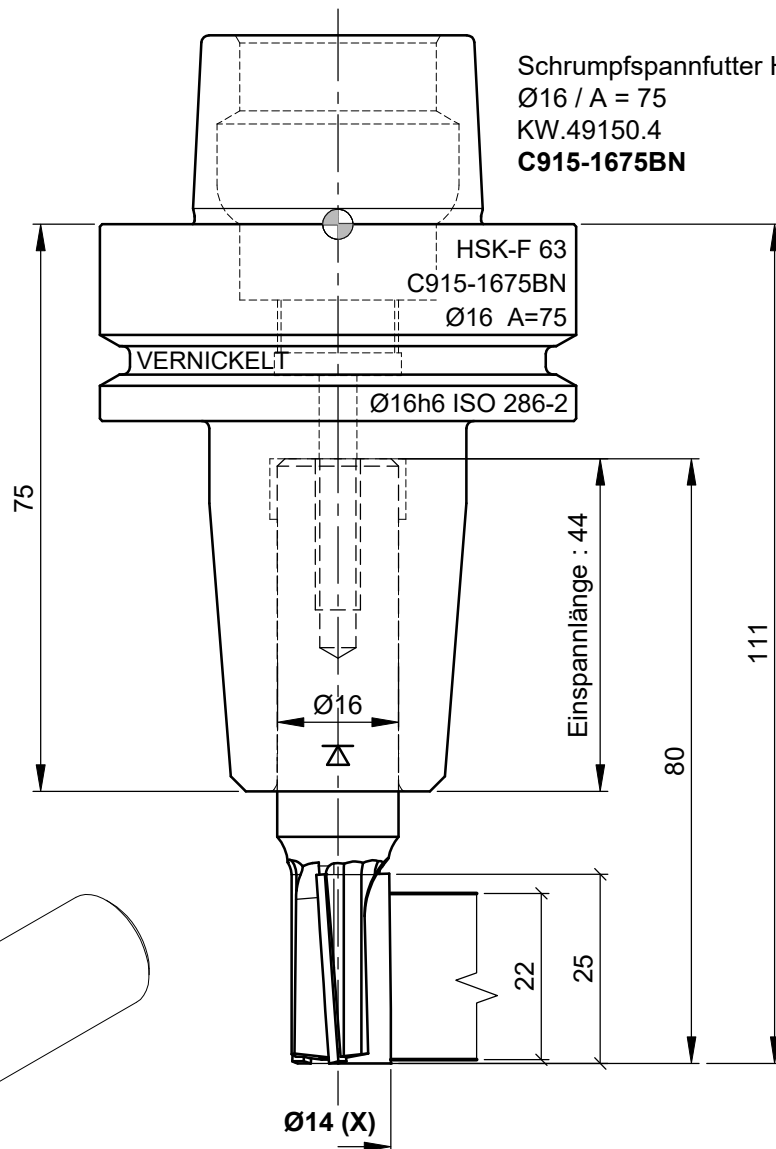
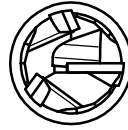

Schrumpfspannfutter HSK-F 63
 Ø16 / A = 75
 KW.49150.4
C915-1675BN

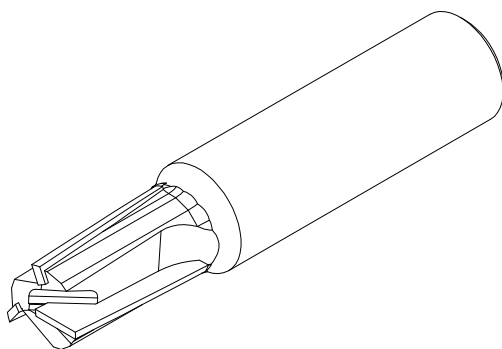

Rechtslauf



Bohrfräsen
 Fliegend eintauchen

Bohrfräsen exzentrisch
 Zirkular eintauchen

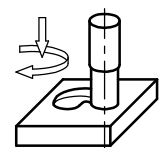
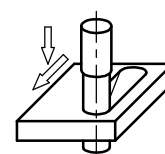

Aigner
 WERKZEUGE

e-mail: office@aigner-werkzeuge.at
 www.aigner-werkzeuge.at

Kom.Burghardt

A-4715 Taufkirchen / Tr.
 WIDLORF 25
 TELEFON (07733) 7583

DATUM: 09.06.2022

NAME: W.Mayrhuber

Blattformat: **A4** M=1:1

Detail.Kw.62171.3

01.32586.7-M1