

# UNM STL 1000-15-270

## H865000

### Product Information Sheet

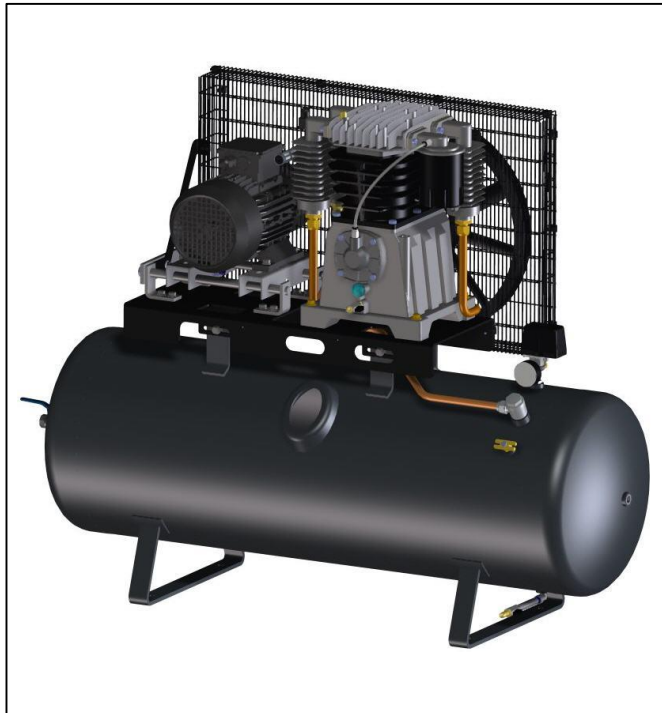

Technical data	H865000
Suction capacity	1000 l/min
Eff. Delivery quantity	790 l/min
Start-up- / switch-off pressure	13/15 bar
Cylinder / Stages	2/2
Tank volume	270 l
Voltage	400 Volt/50 Hz
Drive power	7.5 kW
Speed	995 min <sup>-1</sup>
Noise	82 dB(A)
Dimensions (WxDxH)	1620 x 555 x 1285 mm
Air outlet	¾"
Weight	264 kg

## Product Description

- Stationary compressor
- Compressor for work up to 15 bar
- Smooth running belt driven 2-cylinder unit with 2-stage compression
- Suitable for many jobs in the professional field
- Applications:  
Expansion of compressed air systems,  
Increase reliability
- Highest quality of installed components

# UNM STL 1000-15-270 H865000

## Product Information Sheet



### Quiet running and optimal cooling

due to the new wedge-driven compressor unit with optimal cooling air flow and improved delivery performance

### Reduced noise level

Less noise from new unit

### Compressor with low speed of rotation

Reduced vibrations preserve the compressor components

### Long service life

guaranteed by 15-year warranty against rust-through of vessel

### Space-saving design

Small footprints thanks to optimal arrangement of the components

### Motionless standing position

Standard features include: anti vibration rubber feet

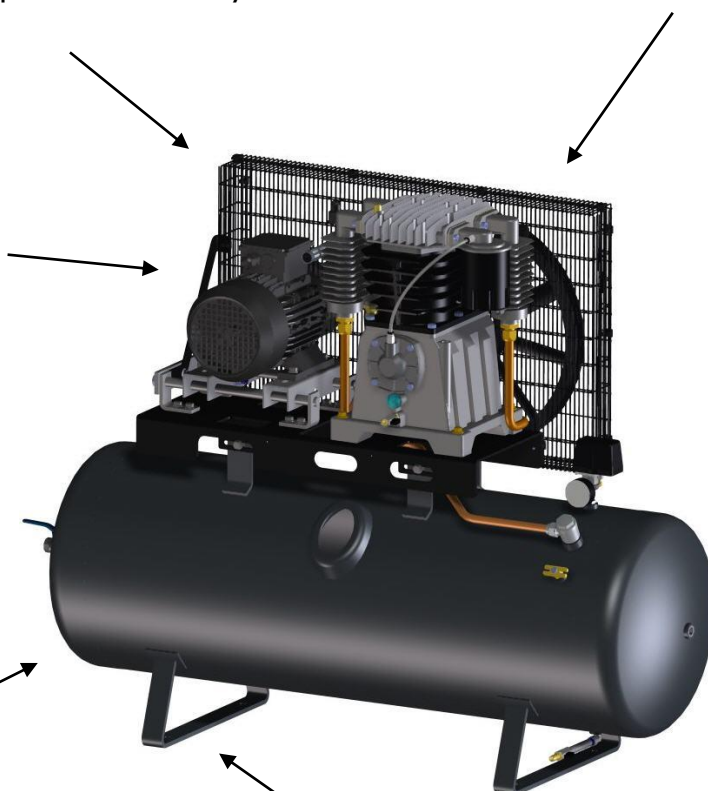

## Further information

Complete equipment

Pressure switch, motor protection, safety and check valve, container pressure gauge, unloaded start

Scope of delivery

Instruction manual

Warranty

- 12 months for professional industrial use  
- 24 months for private use only